



# TORQUE TUBE

**Newsletter of Riley Motor Club Qld Inc July 2014**

[www.rileyqld.org.au](http://www.rileyqld.org.au)



## **In Memory Of Ross Phillips**

**Editor:** Bill Short

[williamshort@aapt.net.au](mailto:williamshort@aapt.net.au) Ph.0738867236

**Next Meeting:** Will be the OGM at the Club Shed Ex CSRIO Grounds Samford on Thursday 10/7/14 at 8 pm, resuming frequency of every second Thursday of the month.

*DISCLAIMER: The Riley Motor Club Qld Inc. accepts no responsibility for the results of contributor's advice, nor does it endorse any services/ goods/ products offered by advertisers. Opinions expressed in this Newsletter are not necessarily those of the Club, its Officers, or its Editor.*

# A Tribute to Ross Phillips

My first visit to a Qld. Riley Club meeting was on Thursday October 8<sup>th</sup> 1987. In those days meetings were held at member's homes, and this one involved a run to Blackwood Street Ipswich. At this stage Sheila and I had only met the French family from whom we had bought our 1929 (8?) Nine. We were met at the door by a Gentleman with a huge black beard who made us most welcome and won me over immediately by offering me a beer. This was Ross!! In those days Ross was Secretary. He also went on to be, at various times, Editor, Treasurer, Club Captain (Or was that Di) and anything else the Club needed him to do. Ross had a love of all Rileys, and rebuilt them with great enthusiasm and much skill. His Holden engined RMA is still I believe in Canberra, His fully rebuilt nine still in Qld., the RMB I have lost track of, and there were many more, but his best Riley in my opinion is Victor, the single seat open wheel race car based on an RMB chassis, with supercharged Pathfinder motor giving great performance. Ross also raced and hillclimbed his Elf with the lowered suspension giving he and Di a rough ride when used for national Rallies. Over the years we have all shared many happy moments with Ross and Di, Club day runs, early morning breakfasts, trips to every State in Australia, and a memorable trip to the UK in 1996 to attend the Combined Clubs Riley Centenary Rally in Coventry. Ross got ill three years ago, and was in hospital for much of the time since, yet kept his interest in the Club and the cars until the end. Every visit or phone call was always about who was doing what, where to next etc., never about the health problems that were afflicting him.

He left us peacefully on Monday June 2<sup>nd</sup> with his family at his side.

Our hearts go out to Diane, Andy, Tom and their families, for there loss. It is much too soon.

Alan Hill

## Agenda/Minutes of Riley Club General Meeting Held on 12 June 2014

### At the Jack Warr Riley Shed in Samford

All members present sadly noted the passing of Ross Phillips and his ongoing contribution recognised. Sympathies were extended to Di and family and Tribute to Ross will appear in the next Torque Tube.

1. The President Ken Lonie declared the meeting open at 2003hrs.
2. **Attendance** – as per the attendance sheet
3. **Apologies** –Brian & Lyn Jackson, Di Phillips, Jack Warr
4. **Minutes** of the General Meeting held on 8/5/14 were moved for adoption as a true and correct record by Alan Hill and seconded by Ian Henderson. **Carried**
5. **Business Arising** – The request from Natalie Ormiston for Riley wedding vehicles has been put to members without a positive response: Ken Lonie has emailed a response to Natalie. Rod Forrest's advice on personalised number plates and other items for sale has not yet received any interest and Ken Lonie has emailed a response to Rod.

There was no business arising that was not dealt with in later business.

### 6. **Secretary's Report and Correspondence**

#### **Inwards –**

Club Magazines from: - 1 X VIC, 2 X SA, 1 X WA, 1 X NSW, 1 X Scotland

Correspondence from:-1. Rowena Patch from 61 May Road Ellengowan has offered several genuine Technical Bulletins and Manuals, including RM's, Pathfinder and some "9" information to the club which Ken has picked up and has available for reference. Ken has thanked Rowena.

2. Query from Graham and Lola Sargent of Victoria seeking any information on their recently renovated RMB, and unfortunately we were unable to help. Secretary to respond.

3. An invitation has been received from Anne Berker to attend the opening night of "Gangsters Galore" on 5 July in Woodford. As the Club has a rather full program for July it was decided to decline the invitation and the Secretary is to respond to Anne.

4. Trevor and Wendy Judd advised that they have sold their RMB to their son and consequently have 2 men's shirts size M and 2 ladies blouses size 14 available. There are also 2 white polo shirts that were acquired from Dorothy Cameron. Please contact Trevor or Wendy should you wish to avail yourself of their offer.

5 Trevor Shields of QHMC is trying to locate two perpetual trophies and seeks advice from anyone knowing their whereabouts.

Membership Received From: Nil

**Outwards** – Response to Rowena Patch from Ken Lonie thanking her for the publications and Technical Bulletins

Moved the inwards correspondence be received and the outwards endorsed.

Seconded by Sheila Hill

**Carried.**

## 7. Treasurers Report May 2014

Balance as per Bank Statement, 1 May 2014 **\$5762.35CR**

### Income

2014 Membership Fees	35.00.
Electronic distributor and sundries (EFT/Bpay)	330.00
Donation	20.00
Interest	<u>0.73</u>

**\$385.73**

### Expenditure

Moreton Bay RC – Shed Rent (outgoings), June (EFT/Bpay)	15.00
W. Short – Editor's expenses (EFT/Bpay)	10.00
L.Thomson – Treasurer's expenses (EFT/Bpay)	<u>5.00</u>

**\$30.00**

Balance as per Bank Statement, 31 May 2014 **\$6118.08CR**

Seconded: Bill Short

**Carried:**

## 8. Report from Club Captain – Greg Mehwa

15 June. Reminder for Newfarm Park at 1000hrs.

23 July. Trip to Caloundra Aerodrome postponed to 15 Sept but to be later confirmed.

12<sup>th</sup> & 13<sup>th</sup> July – Samford Show and organisers are always keen for cars for static display, without entry fees.

13<sup>th</sup> July RACQ Motorfest

20 July. Run to Lost World, Beaudesert area

27<sup>th</sup> July – Jack Warr's 90<sup>th</sup> Birthday celebration at the shed.

Octoberfest reminder

8-9 November. Gold Coast Autorama.

November to be confirmed, viewing of Ken's and Bill's projects.

Shed sorting day postponed until September or October. To be confirmed

September 2015. Keep in mind the Perth National Rally

## 9. Report from Torque Tube Editor –

Bill Short advised that it is business as usual and more contributions are urgently required, including photos with descriptions.

Bill again reiterated that ideally he requires articles 2 weeks before the meeting using Arial 10 point text if possible. Photo's should ideally be sized to 600 X 800.

#### 10. **Report on Jack Warr Riley Shed –**

All of the remaining parts, with the exception of an engine, including a partially complete RM have been picked up from 30 Ashton St Wynnum (David Schock 0428051914), and the Secretary is to formally thank Ross McCormish.

Some parts are still to be added from the spare parts shed to enable restoration of the RM.

The remaining parts have also been picked up from Simon and Helga's and the Club expressed their appreciation to Simon for his generosity in donating so many useful items.

#### 11. **Report from Registrar – Nil.**

#### 12. **Report from Spare Parts –.**As neither Jack nor Graham were in attendance there was no formal report presented.

Ian Henderson, who regularly visits Jack has offered to liaise in the purchase of spare parts available from Jack and can be contacted by club members should Jack not be available.

It was mentioned that at a previous AGM it was moved that electrical parts should be held by Graham McKay: has this happened? The Secretary is to follow up this motion and outcomes and report back to the next meeting.

Ken Lonie will send distributor gear specs to Bill Short for possible manufacture.

#### 13. **Report from Website Coordinator –**Linden is still seeking recent photographs and is currently updating the site.

#### 14. **General Business.**

It was noted that to date there have been two daytime meetings with one to still be held as per the Club minutes.

There will be a sausage sizzle prior to the next meeting on 10 July at 1900hrs, and it was agreed that prior to each future meeting there will be the opportunity for a "cuppa".

Bill Short has details on a recommended radiator repairer, which will be included in the next Torque Tube.

#### 15. **Car Reports-**

Bill Short is currently trialling single pack paint applied with a brush and it is producing a spray like finish.

David has just purchased an RMB from Toowoomba and is taking delivery tomorrow. Bill Short previously restored this car.

Ken Lonie presented a modified XK 150 Jaguar Stainless Steel front hub, which he is modifying to fit his RM special.

**Next Meeting** will be the OGM at the Jack Warr Shed on 10/7/14 at 2000hrs, preceded by a sausage sizzle at 1900hrs, maintaining the frequency of every 2<sup>nd</sup> Thursday of the month.

**Meeting Closed:** Attendees were thanked for their attendance and the meeting closed at 2203hrs

# Jack's 90<sup>th</sup> Celebration Lunch

Sunday 27<sup>th</sup> July 2014 at 12 Midday

Riley Clubhouse, Samford, BYO drinks & \$15pp

A reminder that RSVP's are necessary.

Please and no later than 20<sup>th</sup> July.

For further information & RSVP's please contact

Wendy Lonie Mob: 0417 857075

Ken and Wendy Lonie

44 Benecke Road

Maleny, Qld 4552

0409 613 231

0417 857 075

## EDITOR'S REPORT

Hi Readers,

It must be winter and you are all hibernating again. Come out of your caves and give me some more articles so that I can keep the Torque Tube interesting and relevant to all our members. What interests you, quite possibly interests others.

Cheers.

Bill.



### **Nelson O'Brien's 1957 RMC RR111**

To the person who sent this photo in to the Torque Tube. Please accept the Editor's apology. I have lost the email and am not sure about the context. Could you please get back to me and I will rectify the problem.

<b>THE 2013 RILEY MOTOR CLUB QLD ELECTED COMMITTEE</b>		
PRESIDENT:	Ken Lonie	0409 613 231 <a href="mailto:kenlonie@bigpond.com">kenlonie@bigpond.com</a>
VICE PRESIDENT:	Alan Hill	07 3289 1063 <a href="mailto:alshe@bigpond.com">alshe@bigpond.com</a>
SECRETARY:	Mark Baldock	07 5491 5409 <a href="mailto:norest1@bigpond.com">norest1@bigpond.com</a>
TREASURER:	Linden Thomson	07 3139 1524 <a href="mailto:lindenthomson@optusnet.com.au">lindenthomson@optusnet.com.au</a>
CLUB CAPTAIN:	Greg Mehwa	07 38932657 <a href="mailto:gregmew@bigpond.com">gregmew@bigpond.com</a>
SPARE PARTS OFFICER:	Jack Warr	07 3378 3541
ASSISTANT SPARE PARTS OFFICER:	Graham Mackay	0412 071 903
REGISTRAR:	Matthew Schooneveldt	0432 997 564 <a href="mailto:matt@apmm.com.au">matt@apmm.com.au</a>
EDITOR:	Bill Short	07 3886 7236 <a href="mailto:williamshort@aapt.net.au">williamshort@aapt.net.au</a>
WEB COORDINATOR	Linden Thomson	07 3139 1524 <a href="mailto:lindenthomson@optusnet.com.au">lindenthomson@optusnet.com.au</a>
SHED COORDINATOR	Bill White	07 3289 4282 <a href="mailto:thewhitehouse7@bigpond.com.au">thewhitehouse7@bigpond.com.au</a>

## FOR SALE



### **Riley RMC 3 - Seat ROADSTER. Chassis No. 59SS 4978.**

Restoration project. The car was bought in Sydney in 1967, and has not been driven since 1969. For many of the intervening years it has been garaged, otherwise under car covers. The engine was reconditioned by Geoff McInnes Motors in 1992 and has been indoors ever since. All parts are here, including column gear change linkages. Large steering wheel and dashboard are not original, but instruments are. Some rust in running boards. Car is at Flinders, Mornington Peninsula, Vic. Price \$5,000 as is, including all components and manuals.

Would consider co-operative restoration arrangement providing car were not too far from Melbourne.  
Contact Antony Grage. Mobile 0418 170 395.  
email. [agrage@bigpond.net.au](mailto:agrage@bigpond.net.au)

## Riley Used Spares

RMB	Sump, Rocker Cover, Horns, Fuel tank.
Pathfinder	Fuel Tank, Windscreens & Rear Windows.
RMA/RMB	Electronic Ignitions, including New Distributors.

All parts as/where is. All serious offers considered.  
Contact Bill 0732894282 or thewhitehouse7@bigpond.com.au

## Member Profile

### Ron & Heather Anderson – Townsville



Ron was born in Gympie and attended school there. He did his apprenticeship in plumbing and gas fitting before transferring to Brisbane where he attained a gas engineering degree. After transferring to Mackay, Ron, Heather and their young 14month son relocated to Papua New Guinea as Manager for Guinea Gas. They lived in Port Morseby for 2 years, really enjoying the work and lifestyle. The young family then moved to Maryborough Qld where Ron was first Manager then Regional Manager. A big change in direction ensued with Ron and Heather owning and running a retail appliance centre for the next 37 years. Heather and Ron have 2 sons, 2 grandchildren and have lived in Townsville for 38 years.

He bought his now beautiful cream 1949 1.5L RMB in 1992, after it was discovered in a shed – an absolute

wreck! He had desired to own a Riley since he was a kid in Gympie. His Riley 1949 RMA was restored to a high standard, is a pleasure to drive and is always a favourite at Rallies.

Favourite cuisine – Chinese,

Passions: Family, Riley and restoration of old cars and would like to travel to Canada and Ireland.

He has a great sense of humour and is a true Gentleman

Wish for the World – Peace and harmony

## Coming Events

### July

20 <sup>th</sup>	Gold Coast Swap Mudgeraba		\$4.00
26 <sup>th</sup>	Nambour Swap Showground	54768388	

### August

15 <sup>th</sup> – 17 <sup>th</sup>	Lismore Rally NRVVCC
22 <sup>nd</sup> – 24 <sup>th</sup>	Sunshine Coast Rally

### September

13 <sup>th</sup>	Gympie Swap Showground	54822303
14 <sup>th</sup>	Beaudesert Swap Showground	0414066121
16 <sup>th</sup>	VCCQ Annual Veteran/Vintage Club Rooms	
27 <sup>th</sup>	Historic Truck Gatton Showground	<a href="mailto:hcv@hcvag.com.au">hcv@hcvag.com.au</a>

### October

4 <sup>th</sup>	Maryborough Rally	
19 <sup>th</sup>	Ebbw Vale Swap	0408723800

### November

8 <sup>th</sup> -9 <sup>th</sup>	Gold Coast Autorama
----------------------------------	---------------------

## Of Interest

### Red Back Radiators

**Nambour Radiator Works**  
**62 Coronation Ave**  
**Nambour**  
**54415562**  
**Mark**

**Red Devil**  
**6 Moss Street**  
**Slacks Creek**  
**32092611**  
**Peter**



# THE RILEY ENGINES: 1914

Percy Riley was one of the men behind the British [Riley Motor Manufacturing Company](#). Riley also began manufacturing aeroplane engines, becoming a key supplier in Britain's build-up for World War I. Early aero engines were of the rotary type, such as the [Gnome Monosoupape](#), in which the whole engine rotated about a stationary crankshaft. Riley thought he could reduce the heavy whirling mass (just one disadvantage of the rotary aero-engine) and became interested in axial engines.

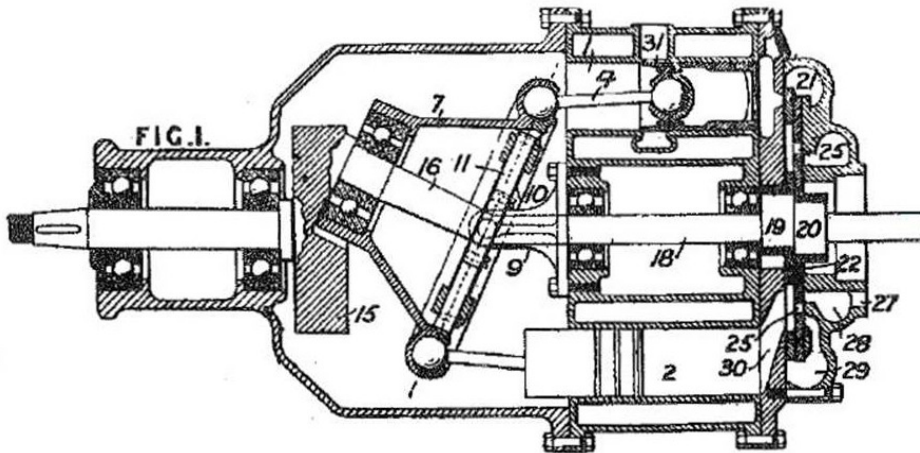

Left: Riley Axial Engine patent, 1914

This drawing comes from British patent 18,204 granted on the First of August, 1914. This patent covered both 2-stroke and 4-stroke designs. Both engines had eight cylinders, unlike other aero engines both radial and rotary, that almost always had an odd number of cylinders to get a good firing order.

Cutaway drawing and information from *Riley- Beyond the Blue Diamond* by David G Styles.

This book is currently out of print but may be reprinted if sufficient demand exists. Email [davidstyles208@yahoo.com](mailto:davidstyles208@yahoo.com) to express your interest.

The version shown above is apparently the liquid-cooled two-stroke version; this was later intended for powering early tanks. Only four of the cylinders produced power; the other four were pumping cylinders for the 2-stroke cycle. This would more than outweigh any advantage in specific power that could be gained by 2-stroke operation. The output shaft is on the left. At right is a rotary disc valve that controlled the transfer of the fuel/air mixture. In a later design (Patent 11933 of August 1915) Riley reduced the number of cylinders to seven, which gave a much better firing order, and introduced compressed-air starting.

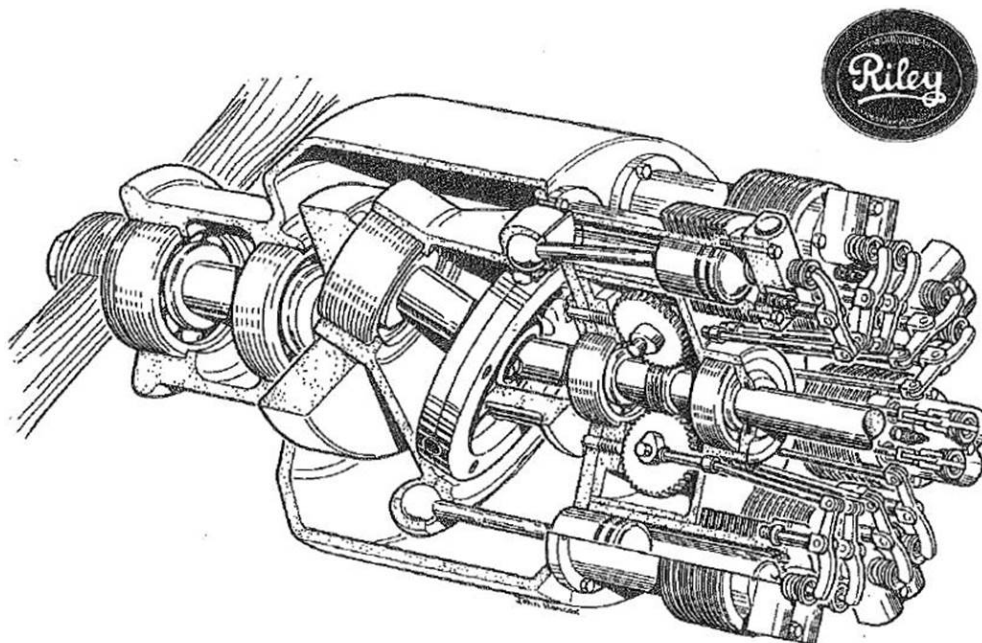

Above: Cutaway drawing of the Riley 4-stroke axial engine, 1914

This drawing shows the air-cooled, 4-stroke version of the Riley axial engine. This time all eight cylinders were power cylinders, and there appear to have been eight separate camshafts, driven by helical gears from the central shaft. The valves were operated by pushrods and rocking levers.

In a later design (Patent 11933 of August 1915) Riley reduced the number of cylinders to seven, which gave a much better firing order, and introduced compressed-air starting.



Left: Percy Riley: date unknown

It is believed that none of the axial engines planned by Percy Riley ever left the drawing board, allegedly due to lack of enthusiasm on the part of the Ministry of Munitions.

An exhibition of David Styles' drawings, some eighty-odd in number, is planned at the California Automotive Museum in Sacramento for late summer 2012. Examples of a Brooklands Riley Nine and an ERA are planned for exhibit with the drawings.

## A Recent Foray Into The Suburbs

Photos Greg Mehwa



# On The Newstead House Run

Photos Greg Mehwa



Atte

ndeeds for the June Riley rally met in the picturesque grounds of Newstead House on the banks of the Brisbane River for morning tea. Mathew and Gloria very ably organised this combined Riley & MG rally.

The weather was perfect, conversation & friendship was in abundance so it wasn't a problem to wile away the time, in fact, the whip had to be cracked to get us moving back into our cars for the next step of the rally. We had detailed direction sheets and all of us ended up at the correct destination – the Brighton Pub for lunch.

Had a great lunch, more camaraderie solving the problems of the world and all things Riley. Good to have Simon S back and thank you Mathew & Gloria for a super day.



**The Club Members And Friends Having A “Cuppa” At Newstead House**

*The Wildflower Rally*

September 24th - 29th 2015

**Non-Binding  
Expression of Interest**

If you are interested in coming to WA for the Rally, we would be grateful if could complete this form to help us in the planning of the event. Please send it to:

Rally in the Valley 2015  
22 Ballack Place  
Oakford WA 6121

or

email: [rallyinthevalley2015@outlook.com](mailto:rallyinthevalley2015@outlook.com)

Name: .....

Contact No: .....

Email: .....

No of people coming: .....

If bringing a Riley, which model: .....

**Accommodation**

Tick Your Preference

- Own Arrangements
- Billet with WA member
- Camp Site
- Van
- Motel
- Luxury Resort
- Cabin
- Other

**Post Rally**

Tick Your Preference

Would you be interested in a post-rally wildflower tour of about 4 days?

If so would you :

- Take your own car
- Go by tourist bus

**Urgent Attention!**

Due to unforeseen circumstances the dates of the 2015 National Rally have been brought forward to Thursday 10th of September to Monday 14th of September. Followed immediately by Post-Rally Wildflower Tour - Tuesday 15th of September to Friday 18th of September.

All email correspondence to:  
[rallyinthevalley2015@outlook.com](mailto:rallyinthevalley2015@outlook.com)