



TORQUE TUBE

Newsletter of Riley Motor Club Qld Inc November 2013

www.rileyqld.org.au



Rileys At The Rock
Courtesy Mal Lorimer

Editor: Bill Short
williamshort@aapt.net.au Ph.0738867236

Please note the change. For this month only, the meeting is the fourth week in the month!

Next Meeting: Will commence at 8pm on **14 November 2013**

**Jack Warr Club Shed
Ex CSIRO Grounds Samford**

DISCLAIMER: The Riley Motor Club Qld Inc. accepts no responsibility for the results of contributor's advice, nor does it endorse any services/ goods/ products offered by advertisers. Opinions expressed in this Newsletter are not necessarily those of the Club, its Officers, or its Editor.

Minutes of General Meeting of the Riley Motor Club of Qld,
Held on 10th October, 2013
At the Jack Warr Clubhouse, Samford

1. The President declared the meeting open at 8.05 pm and thanked Alan Hill for chairing the last meeting in his absence.
2. **Attendance** –. Ken Lonie, Alan Hill, Sheila Hill, Graham Bourne, Bill White, Greg Mewha, Bill Short, Robin Hull, Rod Longden, Robert Wands, Matthew French, Bernie Maudsley, Ian Henderson, Matt Schooneveldt
3. **Apologies** – Mark Baldock, LindenThomson, Wendy Lonie, Ross and Di Phillips, Brian and Lyn Jackson.
4. **Minutes** of the General Meeting held on Thursday 12th September, 2013 were circulated and were moved for adoption as a true and correct record by Rod Longden and seconded by Bill White, Carried.
5. **Business Arising:** There was no business arising which was not dealt with in later business.
6. **Secretary's Report & Correspondence:** In the absence of Secretary Mark Baldock, Alan Hill presented the secretary's report on his behalf.
Inwards Correspondence:
 Completed membership form and subscription received from Mr StJohn Hamilton Herbert of Glenmore, 162 Brauer Road, Rosedale Qld 4674. The form will be tabled and cheque passed to the Treasurer at the next meeting. The Herberts own a red 1950 RMB which they have owned since 1988. Bill Short will forward a paper copy of the Torquetube, as they have no email.

A request for a copy of our certificate of currency of our public liability insurance was received from the Morton Bay Regional Council.

Outwards Correspondence:

Confirmation of our public liability insurance cover was sent to the Moreton Bay Regional Council.

Alan Hill moved that the inwards correspondence be received and the outwards endorsed, seconded by Robin Hull, Carried.

7. **Treasurers Report:** In the absence of Treasurer, Linden Thomson, Alan Hill presented the Treasurer's report on his behalf.

Balance as per Bank Statement of 1 September, 2013	\$3,901.72CR
<u>Income</u>	
Membership Fee - R Harnsworth*	\$35.00
Interest	\$0.48
Sub Total	\$35.48
<u>Expenditure</u>	
Shed Rental for September, 3013**	\$15.00
Sub Total	\$15.00

Balance as per Bank Statement of 30 September, 2013 **\$3,922.20CR**
 Total

- * **Note re Term Deposit:** This matured on 1 October 2013 and was rolled over (capital plus accumulated interest) for six months at the best available BOQ rate of 3.9% for six months.
- ** **Note re Spare Parts Fund Capitation Fee:** The 2013 Capitation contribution of \$380 (76 members at \$5.00) to the Spare Parts Account will be transferred to that account by 12th October. Alan Hill moved that this action be endorsed by the meeting, seconded Bill White. The motion was carried with one dissension.

Accounts for payment

Bill Short presented an account totalling \$42.09 for printer toner cartridge, which will be passed to Linden Thomson at the next meeting.

Alan Hill moved the adoption of the financial report and payment of accounts, seconded by Shiela Hill, Carried.

8. **Report from Club Captain:** Robin Hull reported that 9 cars attended the All British Day and that although there were a large number of cars, public attendance was low, possibly due to lack of advertising.

Coming events include:

- Weekend away at Woodenbong on 26th and 27th October, leaving from the Yatala pie shop at 10.15 am on 26th October. Details for accommodation bookings etc are in the TorqueTube.
- Lunch run to Boreen Point on Sunday 10th November leaving from the Burpengarry BP service Station at 9 am and morning tea in the park at Yandina.
- Gold Coast Autorama rally on 16th and 17th November.
- Club Xmas Party at the Jack Warr Clubhouse, Samford on 15th December. The monthly club meeting will also be held at the same time, commencing at 12.30 pm.
- The National Rally will be held in Mittagong, NSW on 20th to 24th March, 2014.

Expressions of interest have also been called for attendance at the North Queensland Hub Rally to be held in Charters Towers on the 18, 19 and 20 April, 2014. (Easter).

10. **Report from Torque Tube Editor:** Bill Short.
Members were encouraged to submit articles for the Gazette on any topic.
The most recent edition of the TorqueTube has been sent to members, with some emailing problems. These have now generally been resolved.
11. **Report on Jack Warr Riley Shed:** Bill White.
Bill White and others have laboriously washed the walls of the main meeting room of the clubhouse, prior to painting. A working bee to paint the room will be held on Sunday 20th October commencing at 8 am. Bill has purchased the paint, but attendees are asked to bring rollers, trays, roller extensions, drip cloths, brushes and step ladders. Members are asked to attend the working bee if available.
12. **Report from Registrar** Mathew Schooneveldt
Nothing new to report.
13. **Report from Spare Parts:** Jack Warr or Graham Mackay
Ken Lonie explained several minor issues with the club distributors and will arrange to collect the remaining stock from Jack Warr and make the minor adjustments with Robin Hull.

Out of interest, the new distributors have a vacuum advance travel of about five and a half degrees, whereas the original manual advance was about five and three quarters degrees. (close enough). The small ratchet which adjusts the vacuum advance spring tension in the new distributors needs to be rotated around to maximum tension to get the correct rate of response for the Riley 2.5 engine. At any lower tension, the vacuum advance comes fully on as soon as the engine starts and stays fully on. The small ratchet needs to be filed down when in this position, so it does not foul with the rotating magnet.

14. **Report from Website Coordinator** Linden Thompson
Nothing to report as Linden is away.
15. **General Business:** Christmas Party will be held on 15th December at the clubhouse, Samford.

QHMC Survey.

The QHMC has been approached by the Queensland Transport Authority (TMR) with a view to reviewing the current SIVs registration system.

The QHMC has asked all affiliated clubs to vote on 5 different SIVs scheme options. These options were put to the meeting with unanimous support for the existing system but with all Sundays being additional days. (Option 2b). The membership is happy with the existing system, but all Sundays as additional days would be preferred, provided this was at no or little additional cost.

The membership also felt that they were unable and unwilling to be responsible for administering and enforcing the rules when many members are spread throughout Queensland.

The President will forward this information to QHMC.

16. Car reports

Members reported on the status of their various projects. Alan Hill had a lucky call on his way back from the national rally in SA when his oil filter unscrewed and dropped all the oil at a service station. No harm appears to have been done.

Rod Langden has purchased the RMB he has been driving and has now removed the engine and gearbox for overhaul. Matthew French now also has his recently purchased nine on the road.

Next Meeting

14th November, 2013 at 8pm at the Jack Warr Riley Clubhouse at Samford.

Meeting Closed: The President thanked members for their attendance and declared the meeting closed at 10 pm.

For Your Consideration

The President, committee members and attendees of monthly general meetings
The Riley Car Club of Queensland

Dear Ken,

Committee members and

Members able to attend monthly Riley Club meetings,

This is a request to change the time of monthly meetings to a day time period so that more members are able to attend meetings. At the minimum I request that alternate monthly meetings be held during the day on a Saturday or Sunday. I and I think that many other club members would like to attend meeting but cannot because of the following reasons:

- a. The majority of club members are over 50 years of age with reduced reaction time and eye sight for safe night time driving;
- b. Many club members live at a distance from the meeting venue and find it too tiring to drive late at night for the return trip home; and
- c. Many are not able to go out at night because of health and age reasons to attend meetings.

For many years I enjoyed participating in the Western Australia club meetings and served on the committee during different years as secretary, president or magazine editor. Over many years as I have been posted from place to place I have been a member of the WA, NSW, SA and Qld clubs. In recent times I have contributed to the Riley clubs of Australia through the manufacture of inexpensive wiring harnesses and timber frame parts which I have passed on through the spare parts officer.

I am now retired and have time to participate in club activities however because of injuries sustained during Army service I am limited to day time activities only.

I suggest that there are other club members who would participate in monthly meetings if they occurred during daylight hours. Working members could still attend the meeting if it was on a weekend day. I also would hope that more car owners would join the car club if they could attend monthly meetings. This would put the club in a better financial position and make the meetings more enjoyable for a greater number of people.

I hope that the committee would allow this letter to be printed in the club magazine for wider discussion and to generate greater interest in club meetings and activities.

Yours sincerely

Philip Wyllie

(financial member of the Qld Riley Club)

74 Treehaven Way, Maleny Qld 4552

e-mail Philip.w.wyllie@gmail.com

tel: (07) 5499 9826

25 October 2013

Could you please participate in this matter by either attending the meeting and voicing you ideas on the matter or sending a letter or email to one of the committee members? Your opinion matters.

'Rileys Through The Red Centre'

The SA Riley Club organised this rally through central Australia to Darwin for the cooler month of the year, but to coincide with the annual Easter Riley Rally they had to change Easter time to August - no problem!!

The general plan was for the 21 participants (5 'Nines', 4 RMB's, 2 Roadsters, 1 RMA, 1 Drophead, 1 Kestral, 1 BMC Kestral, 1 BMC 4/68 & 5 'moderns') to travel at their own pace and to stop when and where they wanted for however long they wanted, but to try and meet up for dinner and some activity at Coober Pedy, Alice Springs and Katherine on the 11th, 18th and 24th August respectively, with the final destination being Darwin for three days, 28-30th August. This was an ideal arrangement because not everyone has the same interests or wants to push the 130kph speed limit along the Stuart highway!!

Rather than give a day-to-day account of the trip (boring, boring!), I've picked out just some of the many highlights.

Meeting together at the designated places was a marvelous idea. Getting to know people and their cars was both fascinating and often hilarious as we swapped stories and experiences - never a lack of conversation, that's for sure!! It also made you aware of what a huge and diverse country Australia is. But, regardless of what State you come from (or what football code you follow) we can sit down with someone we've never met before and relax over a meal, a beer or just a 'cuppa' at a wayside stop and share common interests.

My first night was at Woomera, having pretty-much wasted the day driving 90kms out to Roxby Downs to visit the Olympic Dam Mine, only to find that tours were conducted just once a week, on a Friday morning - I got there at lunchtime on Friday!! That was very disappointing, but meeting up with some other 'Riley-ites' for dinner, with red wine from the Barossa Valley, made up for it.

Uluru, Kata Tjuta (The Olgas) and Kings Canyon are quite different in their geology and spectacular scenery. I walked around each one and it was impossible not to be in awe, particularly of Uluru, its mass, changing moods and its mystique. It is easy to understand why the aboriginal people have so many dreamtime stories relating to it and so many sacred sites around its base. After all, Uluru is the source of life in that region; animals come to drink from the permanent water holes and feed on the diverse plant species that exist and survive only because 'The Rock' is there. The 10km walk around the base, with all the informative plaques explaining the relevance and importance of different sites, is 'a must', and guaranteed to create enormous respect for Uluru and its keepers.



Happy and relieved that we made it to our first get together: Coober Pedy

but with time up my sleeve and still 5,000 kms to go before rolling into the carport at Townsville, why tempt fate?



Cooling off in the beautiful Florence Falls plunge.



Rileys at 'The Rock' - Uluru cast its spell over these visitors

The Stuart Highway was a completely unexpected and welcome surprise. I had not given it much thought, knowing that at least it was sealed and therefore much better than the horror stretches littered with broken and abandoned cars, caravans and trailers that I'd heard about in the '70's. But to have this wide, smooth two-way strip of road in front of the bonnet all the way to Darwin was fantastic. Road trains, 4WDs with caravans or trailers, even the 'odd' cyclist: no problem! 'Missy', my RMB, loved cruising along at 90 kph hour after hour - no bumps, no squeaks or rattles! It was tempting to push the 130 kph speed limit,

I had been to Kakadu NP several years ago so I opted to visit the Litchfield NP, which is altogether different, being on the edge of a sandstone plateau. Beautiful cascades and waterfalls plunging over the edge of the escarpment have carved out deep, vertical-sided gorges covered with plant species that have adapted to a wet and humid tropical environment, whereas the sparser vegetation on the plateau has to endure harsh dry conditions for most of the year. It was hot travelling (despite both 'air-conditioners' on the RMB being open) and several bushfires were burning out of control in the Park, so a swim in the crystal-clear waters of the Florence Falls plunge pool (having been declared free of 'salties', of course) was an unexpected bonus.

The hospitality showed to us 'Riley-ites' during the Rally was unbelievable. In Alice Springs the MECCA (Motor Enthusiasts Club of Central Australia) hosted a fantastic welcome Bar-B-Q and presented those that had driven more than 3,000 kms to the 'Alice' with an 'Overlander' car badge as a reminder that we were re-enacting the amazing journeys of hardship back in 'the good old days' on nothing more than tracks to the 'Alice', whereas we did it on roads that the old timers would never have thought possible. Our arrival in the 'Alice' coincided with the Henley on Todd Festival and we were invited to take part in the Festival's street parade. Where else in the world would you find a city having a festival to promote something it didn't have? Like, a river with water in it, and then organising a series of boat races? Crazy? Yep, it sure is and it happens in Alice Springs every year, in the dry season of course, and it's a whole lot of fun.

Similarly the KMEC (Katherine Motor Enthusiasts Club) put on a Bar-B-Q for us in their newly acquired, work-in-progress clubroom/shed. After lunch we drove to the large shady and grassed area in front of the City Council Offices for a huge Show and Shine display of cars and motor bikes sponsored by Shannons - some cars and motor bikes had driven the 340kms from Darwin to be in it. Sunglasses were essential to combat the glare from all that chrome and gleaming paint work. The biggest surprise for me on the day occurred when 'Missy' was awarded the 'Best British' trophy -that wash and bit of TLC in the morning must have been the clincher!

The boat trip along the Katherine Gorge is another 'not to be missed' activity. Simply spectacular, with fascinating rock formations carved out by the river and fantastic scenery around every bend. Only one 'salty' was spotted during the two-hour trip and I was surprised to learn that crocodile numbers have been decimated as a result of the poisonous cane toads invading the water way - what an environmental disaster that introduced species has been.



Lining up for a king-size Bar-B-Q in the KMEC clubroom

Darwin just blew us away!! Fifteen Rileys, five 'moderns' and cars from the Darwin Car Club assembled 35kms out of Darwin to be escorted by a Shannons car with yellow lights flashing into Darwin and through the CBD - the lunchtime crowds loved it; waving, taking photos and enjoying the spectacle of these amazing 55-80 year-old cars that had just driven more than 3,000kms to their city. The convoy continued on to the old heritage-listed Qantas Hangar, which doubles as a club room and workshop for the Darwin Car Club, to be met by TV cameras and newspaper reporters.

That evening we were treated to a wonderful dinner and social evening under the stars outside the hanger, courtesy of Shannons. Darwin is a vibrant city at 'the top end' with plenty to see and do. The Darwin War Museum is another 'must'. The devastation caused by the Japanese bombing was shocking, but the loss of life and the bravery shown by an unprepared, under-resourced defence force against all odds was gut-wrenching. Shamefully, most of us had no idea the bombing raids continued for two years, not just the two initial raids we hear about - such is the lack of Australian history in our school curriculum!

I'm not into markets very much but the Mindil Beach market is quite something. The range of foods to eat while walking around or sitting on the beach watching a brilliant sunset, and the 'stuff'



'Missy' didn't miss a beat the whole trip. Here she is beside the 'Dachy kennel'



One of many 'termite people' along the Highway



Loved this sign at the Barkly Roadhouse



Moving off in convoy for the last 35kms into

for sale, are unbelievable. Then, to watch some of the younger generation dancing on a sand dune, silhouetted against the evening sky all to the enchanting throb of a didgeridoo was pure magic!!

The farewell dinner at the Trailer Boat Club was a mixture of relief (that we'd made it), sadness (that it was all over) and varying degrees of exhaustion. Bev Wilson (Rally Director) was thanked and applauded for attempting and pulling off such an ambitious and thoroughly enjoyable rally. There were lots of hugs, handshakes and back-slapping with wishes for a safe, trouble-free trip home, together with invitations

to next year's Riley Rally in Mittagong NSW, and rallies in New Zealand and South Africa. The next day we set off in our 'trusty steeds' for the 5-7 day drive back home,

hopefully making the right choice of south, east or west, at Katherine or Three Ways!!

Summary:

For those who might be interested in some figures relating to both rallies (4-day SA Rally and the Red Centre Rally), check out the following, keeping in mind that I camped with a swag and had a single burner gas stove to boil water for tea, coffee, noodles or soup for brekkies and lunches to keep costs down, but had most dinners at a hotel or restaurant. The 1937 Riley Kestral brought out from England to take part in the rally was the only car not to reach Darwin; she developed a major gearbox problem in Alice Springs and had to be transported back to Adelaide, then England.

Total distance travelled (T'ville-Nuriootpa-Port Augusta-Darwin-T'ville:10,125kms
Time away from home: 5 weeks
Cost of petrol (Max price \$2.26 at Kings Canyon, Av price \$1.78): \$2,280
Engine oil used (including an oil change (5L) in Alice Springs):17 litres
No. of 'freebie' nights with friends:4
No. of nights camping:19
No. of night's accommodation in hotels or caravan Park cabins:12
Av. fuel economy for the whole trip:21.3 mpg
Total cost for the two Rallies:\$4,400 (approx.)

Mal Lorimer

SHED REPORT

Last Sunday, seven members arrived at the club shed to repaint the meeting room. In a great effort this team applied two coats to the room. The end result is a great improvement to our meeting room. Everyone attending the Christmas luncheon & meeting will be very pleasantly surprised. The painting team thanks the cook,

Bill White
Shed Coordinator.

Editor Report

Hi Readers,

Great job done by our weekend warriors on the "SHED", they are to be congratulated on their efforts.

Many thanks to Mal Lorimer for his great article on the Red Centre Run. It makes my job a lot easier when I get such great assistance from the members. Keep it up.

Cheers.
Bill.



1929 Auburn Cabin Speedster

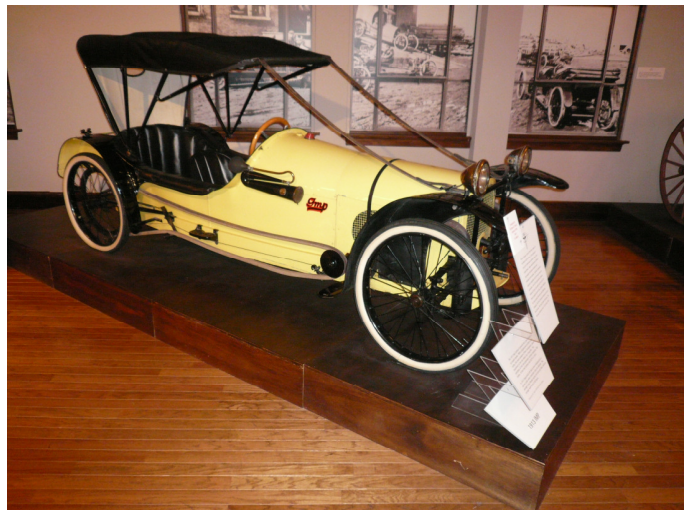

1913 Imp Cycle Car

Our Intrepid Weekend Squad

Bill White, Ken Lonie, Bernie Maudsley, Robin & Barbara Hull, Rod Longden, Alan & Shelia Hill, Mark Baldock.
My apologies for anyone I might have missed. Well done all.



THE 2013 RILEY MOTOR CLUB QLD ELECTED COMMITTEE		
PRESIDENT:	Ken Lonie	0409 613 231
VICE PRESIDENT:	Alan Hill	07 3289 1063
SECRETARY:	Mark Baldock	07 5491 5409 norest1@bigpond.com
TREASURER:	Linden Thomson	07 3139 1524
CLUB CAPTAIN:	Robin Hull	07 54964953
SPARE PARTS OFFICER:	Jack Warr	07 3378 3541
ASSISTANT SPARE PARTS OFFICER:	Graham Mackay	0412071603
REGISTRAR:	Matthew Schooneveldt	07 3263 1986
EDITOR:	Bill Short	07 3886 7236 williamshort@aapt.net.au
WEB COORDINATOR	Linden Thomson	07 3139 1524
SHED COORDINATOR	Bill White	07 3289 4282

Club Captains Report

A most enjoyable weekend, the club run to Woodenbong on the 26th and 27th of October. Five cars made the trip. We started from the Yatala pie shop(where most could not resist the temptation to sample one of their famous pies) and travelled down the highway until we turned of at Nerang. Even though the car racing was on at Southport the traffic to Nerang was not too bad. From Nerang we travelled through the Numinbah valley past natural arch to Chillingham. From there we went to Tyalgum (the heart of the Caldera or the heart of an ancient volcano) where we had lunch. Lunch didn't need to be much after Yatala. There is supposedly a sealed road from Tyalgum to the Kyogle road but the fearless leader failed to find it and unfortunately we travelled for some time on dirt road.

On to Kyogle and then made the final run to Woodenbong. From Nerang on the scenery was quite spectacular the road mostly hilly and winding a most enjoyable drive. The publican at Woodenbong was eager to please and dinner was just great, the group being boisterous enough to entertain the other guests.

On Sunday a cooked breakfast was the order of the day and really sufficient for the rest of the day. The return run was back towards Kyogle and on to what is called the Lion's road, which heads back to Beaudesert. The locals wanted a road back over the Mc Pherson ranges through the Richmond gap which would be considerably shorter than the existing route and when the Government would not provide the Lion's clubs of Kyogle and Beaudesert got together and built the road. The last of the road was sealed in 1995. The road goes over many creek crossings, is very winding and most scenic. It tracks alongside the main northern rail line and beside it there is a viewing platform which overlooks the "Border Loop" where the rail line goes through a hill and in a large circle in order to gain height. It is quite famous in train parlance. We had smoko /lunch in Beaudesert before going our separate ways.

Coming Events

November

Sunday 10th

Lunch run to Boreen Point. Starting from the BP service centre on the West side of the highway south of Caboolture at 9.00 am. Smoko is at the rest area South of Yandina at about 10.15.

Saturday 16th Sunday 17th

The Gold Coast Autorama

December

Sunday 15th

Christmas party at the shed there will be a short general meeting commencing at 10.00am prior to the party

April

18th, 19th, 20th,

Townsville Veteran Vintage & Historic Motor Club inc. will be holding a rally in Charters Towers expressions of interest are invited hubrally2014@iinet.net.au

Meets and Show Events

November

3 rd	Perga Ipswich C&M Club Swap & Shine.	3281 3524
24 th	Beaudesert Little A's Swap Showgrounds.	0409 488912

THE 2013 RILEY MOTOR CLUB QLD ELECTED COMMITTEE		
PRESIDENT:	Ken Lonie	0409 613 231
VICE PRESIDENT:	Alan Hill	07 3289 1063
SECRETARY:	Mark Baldock	07 5491 5409 norest1@bigpond.com
TREASURER:	Linden Thomson	07 3139 1524
CLUB CAPTAIN:	Robin Hull	07 54964953
SPARE PARTS OFFICER:	Jack Warr	07 3378 3541
ASSISTANT SPARE PARTS OFFICER:	Graham Mackay	0418 719 309
REGISTRAR:	Matthew Schooneveldt	07 3263 1986
EDITOR:	Bill Short	07 3886 7236 williamshort@aapt.net.au
WEB COORDINATOR	Linden Thomson	07 3139 1524
SHED COORDINATOR	Bill White	07 3289 4282

RILEY CHRISTMAS LUNCH

*15th December 2013 at 12.30pm
At the Jack Warr Riley Shed, Samford.*

*The Club will supply the ham and turkey.
Members will be asked to bring a salad and/or sweets
and BYO drinks*

*Please ring Wendy Lonie 0417 857075 re attendance
and "what to bring" prior to
December 8th.*

*The Meeting room has been repainted and
we would love to see a good roll up of Queensland
Riley Members.*

Some Ideas For Those Who Want To Play

More detailed drawings are available from the Editor.

PANEL BEATING GUIDE

COURTESY :- BILL SHORT

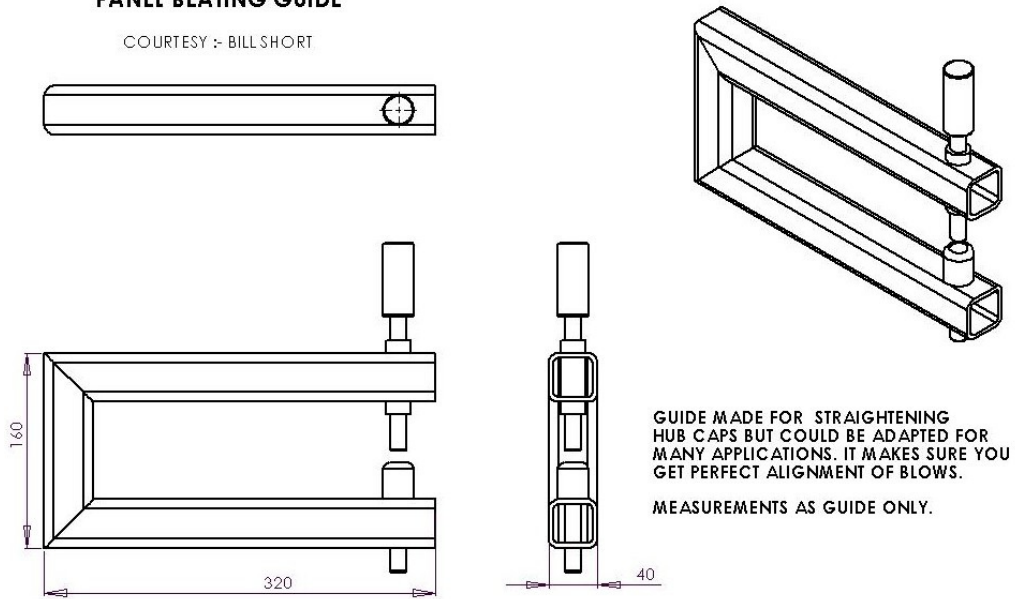

PANEL BEATING PINCERS

COURTESY :- BILL SHORT

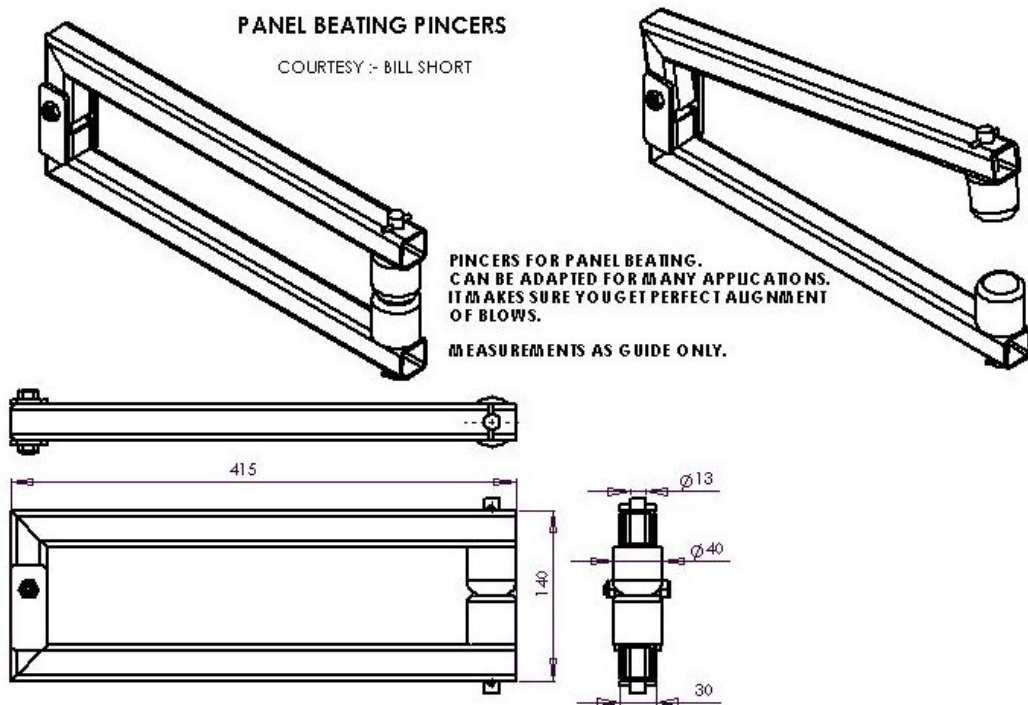

BRAKE SHOE REMOVAL TOOL
 COURTESY ROBIN HULL
 MATERIAL : MILD STEEL

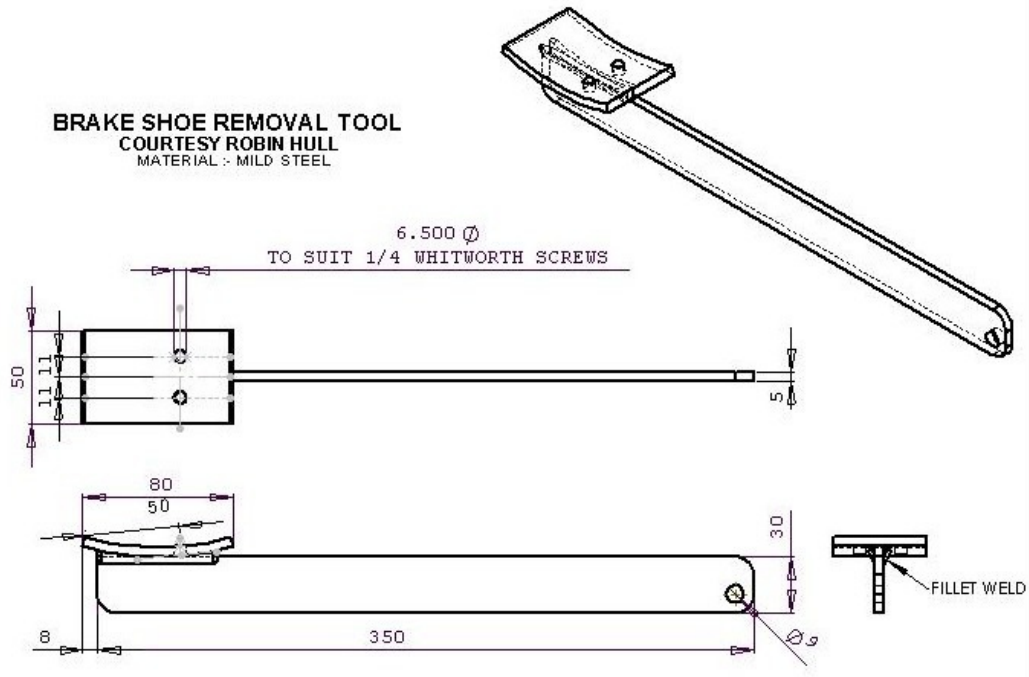

PETROL LINE PULLER
 COURTESY ROBIN HULL
 MATERIAL : MILD STEEL

